

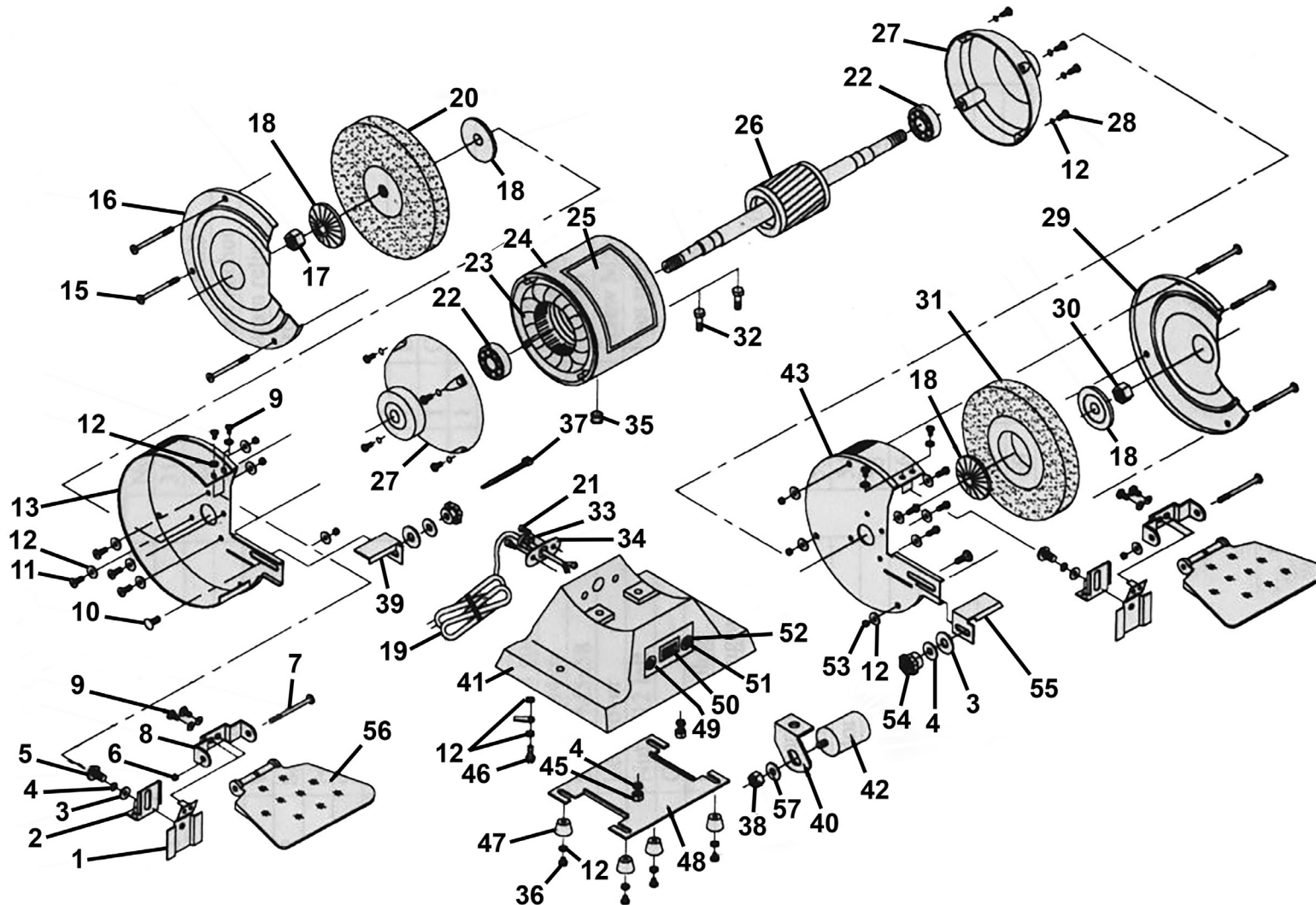

Parts Information:  
150mm Heavy-Duty Bench Grinder with Wire Wheel 450W/230V  
Model No: BG150XW/99.V4



**NOTE:** It is our policy to continually improve products and as such we reserve the right to alter data, specifications and component parts without prior notice.

There may be alternative versions of this product, please contact us should you require this information.

**IMPORTANT:** No liability is accepted for incorrect use of product. Spare parts must be fitted by a competent person

**WARRANTY:** Guarantee is 12 months from purchase date, proof of which will be required for any claim.

Jack Sealey Ltd t/a Sealey Group, Kempson Way, Suffolk Business Park, Bury St Edmunds, Suffolk, IP32 7AR UK

Jack Sealey (EU) Ltd t/a Sealey Group, Farney Street, Carrickmacross, Co. Monaghan, A81 PK68 Ireland

Tel: 01284 757500 • Email: sales@sealey.co.uk • Web: www.sealey.co.uk



TM

Parts Information:  
**150mm Heavy-Duty Bench Grinder with  
 Wire Wheel 450W/230V  
 Model No: BG150XW/99.V4**

Item	Part No.	Description
1	BG150XW99V301	Eyeshield Bracket
2	BG150XW99V302	Bracket Support
3	RW619.S	Repair Washer M6 x 19mm
4	FWM6.S	Flat Washer M6 Zinc
5	MSP610.S	Machine Screw Pan Head Phillips M6 x 10mm
6	SN4.S	Steel Nut M4 Zinc
7	MSP460.S	Machine Screw Pan Head Phillips M4 x 60mm
8	BG150XW99V308	Eyeshield Holder
9	MSP46.S	Machine Screw Pan Head Phillips M4 x 6mm
10	CBN616.S	Coach Bolt M6 x 16mm
11	MSP510.S	Machine Screw Pan Head Phillips M5 x 10mm
12	FWM5.S	Flat Washer M5
13	BG150XW99V313	Left Wheel Guard
15	MSP560.S	Machine Screw Pan Head Phillips M5 x 60mm
16	BG150XW99V316	Left Cover, Wheel Guard
17	BG150XW99V317	Nut M12 Left
18	BG150XW99V318	Wheel Flange
19	BG150XW99V319	Cord and Plug
21	BG150XW99V321	Screw M5 x 6mm
22	BG150XW99V322	Bearing 80202ZZ
23	BG150XW99V323	Stator
24	BG150XW99V324	Motor Case
25	BG150XW99V325	Label
26	BG150XW99V326	Rotor
27	BG150XW99V327	End Casing
28	BG150XW99V328	Screw M5 x 16mm
29	BG150XW99V329	Right Cover, Wheel Guard
30	BG150XW99V330	Nut M12
32	BG150XW99V332	Bolt M6 x 25mm
33	BG150XW99V333	Cord Grip
34	BG150XW99V334	Strain Relief

Item	Part No.	Description
35	BG150XW99V335	Protection Ring
36	MSP514.S	Machine Screw Pan Head Phillips M5 x 14mm
37	BG150XW99V337	Cable Tie
38	SN8.S	Steel Nut M8 Zinc
39	BG150XW99V339	Tool Rest, Left
40	BG150XW99V340	Holder, Capacitor
41	BG150XW99-V4-41	Base
42	BG150XW99V342	Capacitor
43	BG150XW99V343	Right Wheel Guard
45	SN6.S	Steel Nut M6
46	BG150XW99V346	Screw M5 x 8mm
47	BG150XW99V347	Rubber Foot
48	BG150XW99V348	Base Plate
49	BG20099V3.49	Cover, Switch
50	BG150XW99V350	Switch, Red Rocker (On/Off) 16A/125V
51	MSP310.S	Machine Screw Pan Head Phillips M3 x 10mm
52	FWM3.S	Flat Washer M3 Zinc
53	SN5.S	Steel Nut M5 Zinc
54	BG150XL/96-TF	Tool Rest Fixing Complete
55	BG150XW99V355	Tool Rest, Right
56	BG150XD/99-01	Eyeshield, 110/85 x 80 x 2mm
57	FWM8.S	Flat Washer M8
		<b>Please Choose Required Grinding/Wire Wheel</b>
20	BG150/15	Grinding Stone Ø150 x 20mm Ø32(13)mm Bore A60P Fine
20	BG150/16	Grinding Stone Ø150 x 20mm Ø32(13)mm Bore A36Q Coarse
31	BG150/WW1	Wire Wheel Ø150 x 13mm Ø13mm Bore Narrow
31	BG150/WW2	Wire Wheel Ø150 x 20mm Ø13mm Bore Wide

**NOTE:** It is our policy to continually improve products and as such we reserve the right to alter data, specifications and component parts without prior notice. There may be alternative versions of this product, please contact us should you require this information.

**IMPORTANT:** No liability is accepted for incorrect use of product. Spare parts must be fitted by a competent person

**WARRANTY:** Guarantee is 12 months from purchase date, proof of which will be required for any claim.

Jack Sealey Ltd t/a Sealey Group, Kempson Way, Suffolk Business Park, Bury St Edmunds, Suffolk, IP32 7AR UK

Jack Sealey (EU) Ltd t/a Sealey Group, Farney Street, Carrickmacross, Co. Monaghan, A81 PK68 Ireland

Tel: 01284 757500 - Email: sales@sealey.co.uk - Web: www.sealey.co.uk