

# baridi

## Integrated 60cm Induction Hob with 4 Cooking Zones 2900W Output

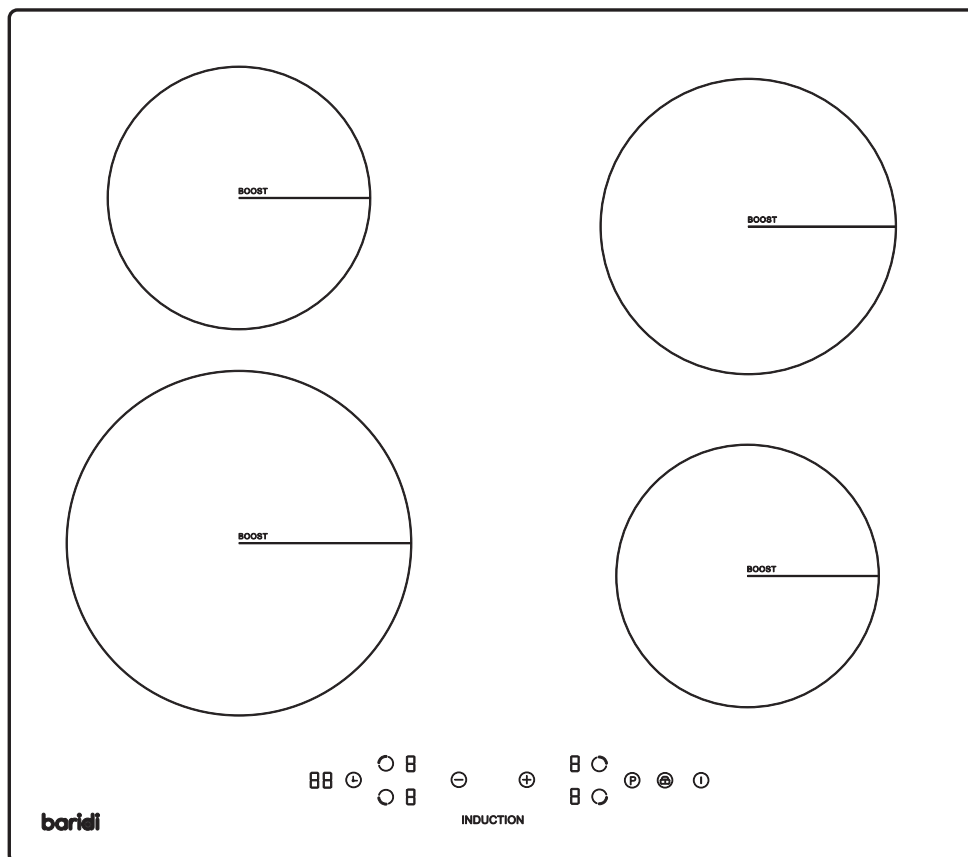

**Model: DH177.V2**

Thank you for purchasing a Baridi product. Manufactured to a high standard, this product will, if used according to these instructions, and properly maintained, give you years of trouble free performance.

## Important Information

Please read these instructions carefully. Note the safe operational requirements, warnings & cautions. Use the product correctly and with care for the purpose for which it is intended. Failure to do so may cause damage and/or personal injury and will invalidate the warranty. Keep these instructions safe for future use.



Refer to instruction manual



**Warning!**  
Hot surface



**Warning!**  
Can cause Fire



Indoor use only



**Warning!**  
Electricity

## Specification

Model	DH177.V2
Product Colour	Black
Installation	Built-in
Surface	Ceramic Glass
Type	Induction
Controls	Touchscreen
Number of Hobs	4
Power Features	9 Power Settings + Boost per zone
Power	2900W
Electrical Class	Class 1
Supply	220-240V
Cable Length	1m
Plug	3-pin 13A
Product Dimensions	590 x 520 x 58mm
Nett Weight	7.95kg



## Safety instructions

### ELECTRICAL SAFETY

- **WARNING!** It is the user's responsibility to check the following:  
Check all electrical equipment and appliances to ensure that they are safe before using. Inspect power supply leads, plugs and all electrical connections for wear and damage.
- Electrical safety information: It is important that the following information is read and understood.
- Ensure that the insulation on all cables and on the appliance is safe before connecting it to the power supply.
- Regularly inspect power supply cables and plugs for wear or damage and check all connections to ensure that they are secure.
- If the supply cord is damaged, it must be replaced by the manufacturer, its service agent or similarly qualified persons in order to avoid a hazard.
- **WARNING!** Important: Ensure that the voltage rating on the appliance suits the power supply to be used and that the plug is fitted with the correct fuse (see Specification table).
- **DO NOT** pull the plug from the socket by the cable.
- **DO NOT** use worn or damaged cables, plugs or connectors. Ensure that any faulty item is repaired or replaced immediately by a qualified electrician.
- This product is fitted with a **BS1363/A** 3 pin plug.
- If the cable or plug is damaged during use, switch the electricity supply and remove from use.
- Ensure that repairs are carried out by a qualified electrician.

### GENERAL SAFETY

- **WARNING!** The warnings, cautions and instructions in this manual cannot cover all possible conditions and situations that may occur. It must be understood by the operator that common sense and caution are factors which cannot be built into this product, but must be applied by the operator.
- The appliance and its accessible parts become hot during use. Care should be taken to avoid touching heating elements.
- Children shall **NOT** play with the appliance.
- Cleaning and user maintenance shall not be made by children without supervision.
- Accessible parts may become hot during use. Young children should be kept well away when in use.

### OPERATIONAL SAFETY

- **WARNING!** Unattended cooking on a hob with fat or oil can be dangerous and may result in fire. **NEVER** try to extinguish a fire with water but switch off the appliance and then cover flame e.g. with a lid or a fire blanket.
- **CAUTION:** The cooking process has to be supervised. A short-term cooking process has to be supervised continuously.
- **WARNING!** Danger of fire: do not store items on the cooking surfaces.
- **WARNING!** Use only hob guards designed by the manufacturer of the cooking appliance or indicated by the manufacturer of the appliance in the instructions for use as suitable or hob guards incorporated in the appliance. The use of inappropriate guards can cause accidents.

- Metallic objects such as knives, forks, spoons and lids should not be placed on the hob surface since they can get hot.
- **WARNING!** If the surface is cracked, switch off the appliance to avoid the possibility of electric shock.
- After use, switch off the hob element by its control and do not rely on the pan detector.
- **IMPORTANT!** The hob is not intended to be operated by means of an external timer or separate remote-control system
- This piece of equipment is solely designed for use by a responsible adult/professional user who has received adequate training on its operation & safety risks.
- **DO NOT** allow paper or cloth to come in contact with any heating element.
- It is specifically designed for use when heating or cooking food. The use of corrosive chemicals in heating or cleaning will damage the appliance and could result in injury.
- If food being prepared should ignite, switch off the hob and disconnect from supply power.
- Only use utensils that are suitable for use with ceramic hobs.
- **WARNING! DANGER OF EXPLOSION!** Liquids and other foods must not be heated in sealed containers since they are liable to explode.
- **DO NOT** allow any accessories or electric cables to contact the hot parts of the appliance.
- **HOT SURFACES! RISK OF BURNS!** During use the appliance becomes hot.
- **WARNING!** Accessible parts may become hot during use. Young children should be kept away.
- Never move racks or pans when they are hot. Wait until they cool.
- **IMPORTANT!** Always switch off the electricity supply at the mains during installation and maintenance.
- The ceramic hob is intended for household use only.
- Ensure that small items of household equipment, including connection leads, do not touch the hob as the insulation material of this equipment is usually not resistant to high temperatures.
- **DO NOT** leave the ceramic hob unattended when frying. Oils and fats may catch fire due to overheating or boiling over.
- **DO NOT** switch on the hob until a pan has been placed on it.
- **DO NOT** put pans weighing over 25kg on the hob.
- **DO NOT** use the ceramic hob in the event of a technical fault. Any faults must be fixed by an appropriately qualified and authorized person.
- In the event of any incident caused by a technical fault, disconnect the power and report the fault to the service centre to be repaired.

## General information

- This appliance is designed for domestic household use and must be built into a standard kitchen cabinet or housing unit.
- The appliance surfaces will become hot during use and retain heat after operation.
- Please dispose of the packaging material carefully. Packaging material can be dangerous to children.
- **DO NOT** allow cable to come into contact with the heating areas of appliance.
- **DO NOT** install the appliance next to curtains or soft furnishings.
- The appliance must be placed in such a way that the power supply is accessible at all times.
- Before connecting the appliance to the power supply, check that the power supply voltage and current rating corresponds with the power supply details shown on the appliance rating label.
- Never use a damaged appliance! Disconnect the appliance from the power source and contact your supplier if it is damaged.
- Danger of electric shock! Do not attempt to repair the appliance yourself. In case of malfunction, repairs are to be conducted by suitably qualified personnel only.
- To avoid damaging the cord, do not squeeze, bend or chafe it on sharp edges. Keep it away from hot surfaces and open flames as well.
- Lay out the cord in such a way that no unintentional pulling or tripping over it is possible.
- **DO NOT** open the appliance casing under any circumstances. Do not insert any foreign objects into the inside of the casing.
- Always operate the appliance on a level, stable, clean and dry surface. Protect the appliance against heat, dust, direct sunlight, moisture, dripping and splashing water.

## Installation

### ELECTRICAL CONNECTION

- Review and understand the Safety Instructions before installing this unit.
- Dellonda strongly recommend this work to be conducted by suitably qualified personnel only.
- Before connecting the appliance, make sure that the supply voltage marked on the Rating Plate corresponds with your mains supply voltage.
- The mains cable must not touch any hot metal.
- Care must be taken to ensure that the temperature of the mains supply cable does not exceed 50°C.
- If the mains supply cable is damaged, then it must be replaced by an appropriate replacement.

### INSTALLING THE HOB INTO THE KITCHEN WORK SURFACE

- The kitchen area should be dry and aired and equipped with efficient ventilation. When installing the hob, easy access to all control elements should be ensured.

## POSITIONING THE APPLIANCE

- The kitchen units that are in direct contact with the appliance must be heat-proof (min. 95°C).
- **IMPORTANT!** Check the ventilation requirements before proceeding with installation. See fig.1.
- Minimum ventilation clearance requirements are 76cm above the hob, 5cm below the underside and 2cm from the rear and must include a 5mm front ventilation gap (fig.1).
- Make sure the surface is level and square and that no part interferes with the space required for installation.
- Mark out the positioning for the hob (fig.2).
- The hob requires a rectangular hole of 560mm wide by 490 mm deep and must be positioned so that there is a minimum of 50mm on all sides.
- Carry out all cutting of the unit and work surface then carefully remove shavings or sawdust before inserting the appliances.
- Apply the seal strip (supplied) to the underside edge of the hob, and leave approx. 3mm from the edge of the glass (see fig.2).
- Cut any excess and bring the two ends of the seal together so they match.
- **IMPORTANT!** Do not use a silicon sealant to seal the appliance against the aperture. This will make it difficult to remove the hob from the aperture in future, particularly if it needs to be serviced.
- Fix the brackets (4 pcs) on the front side and rear side by screw (fig.3).
- Lower the hob into the cut-out, and centre it. Ensure that the front edge of the hob is parallel to the front edge of the work surface.
- **IMPORTANT!** You must observe the ventilation requirements shown in fig.1.
- **IMPORTANT!** There are ventilation spaces around the outside of the hob. **YOU MUST** ensure that these spaces are not blocked by the work top, when you put the hob into position (see fig.1).

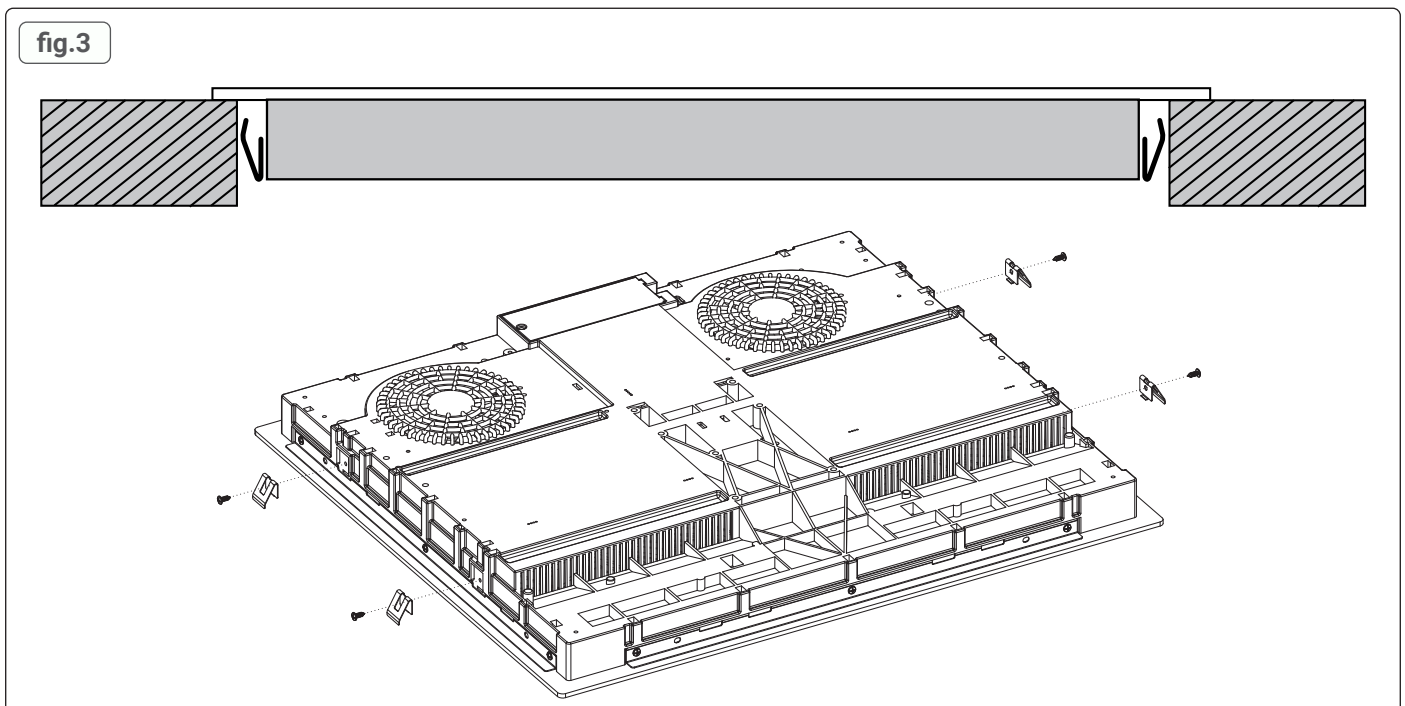
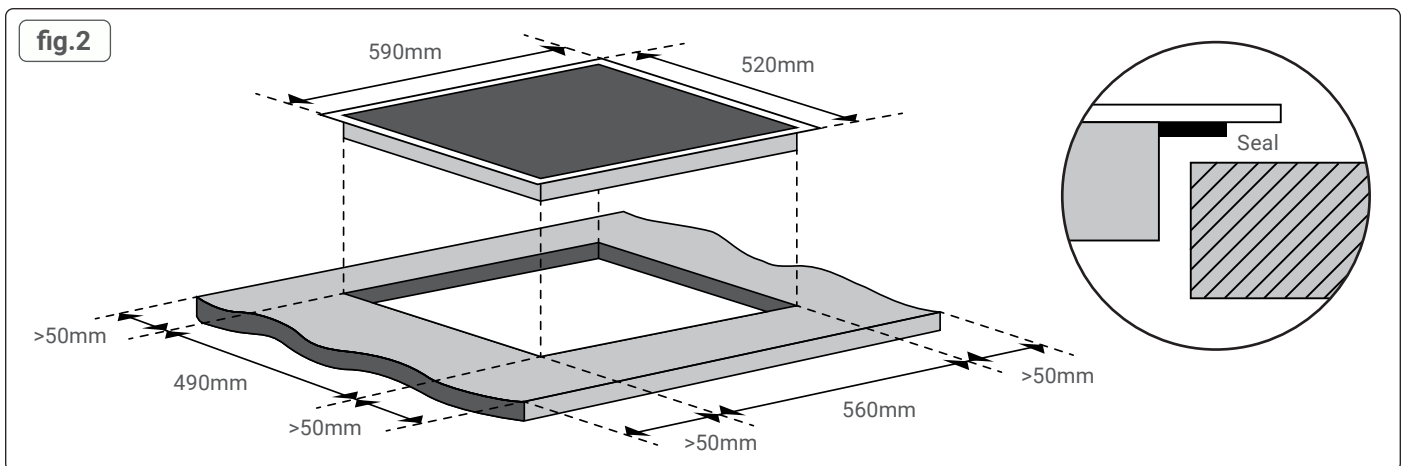
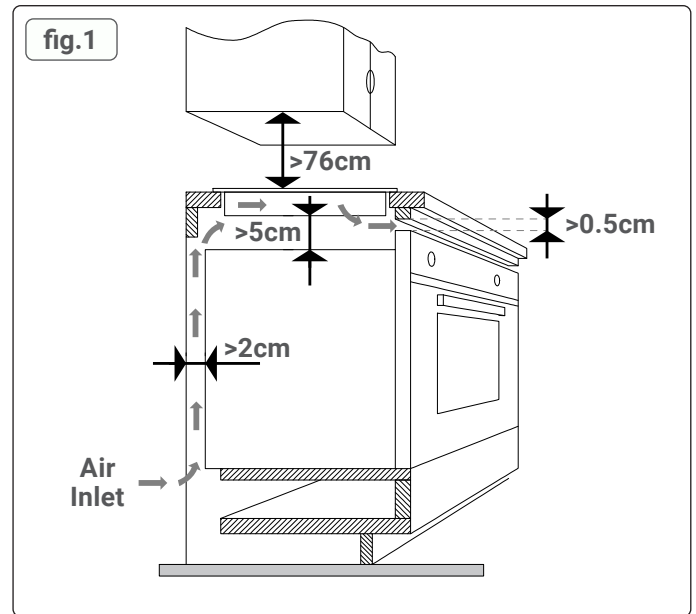
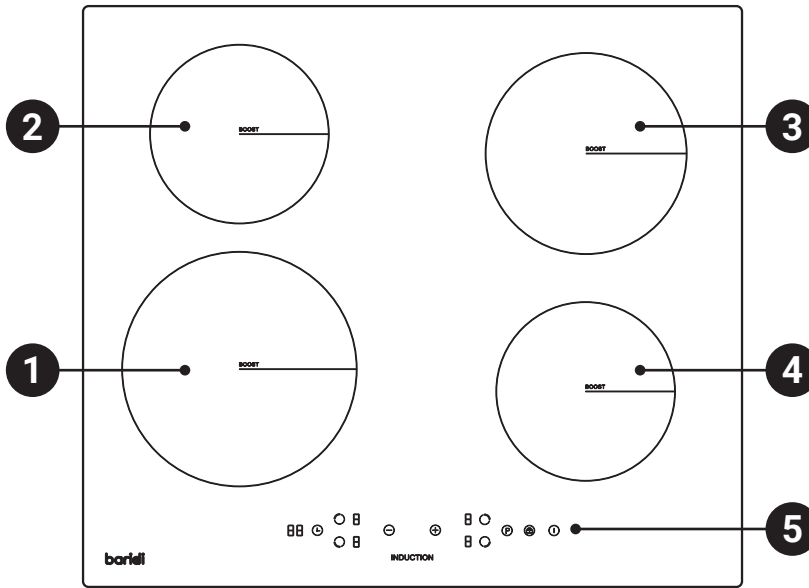

fig.4

Top View



1	Zone 1 - 1800/2100W max.
2	Zone 2 - 1200/1500W max.
3	Zone 3 - 1800/2100W max.
4	Zone 4 - 1200/1500W max.
5	Control Panel
6	Zone 2 Select + Power Level
7	Zone 3 Select + Power Level
8	Timer + Timer Display
9	Zone 1 Select + Power Level
10	Power Level/Timer Decrease
11	Power Level/Timer Increase
12	Zone 4 Select + Power Level
13	Power Boost
14	Child Lock
15	On/Off

Control Panel

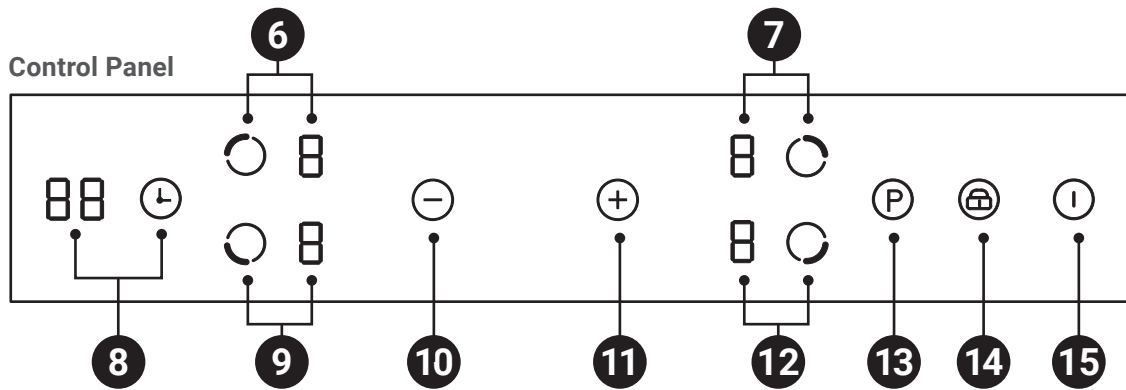

## Operation

### CHOOSING THE CORRECT COOKWARE

- Only use cookware with a base suitable for induction cooking. Look for the induction symbol on the packaging or on the bottom of the pan.
- You can check whether your cookware is suitable by carrying out a magnet test. Move a magnet towards the base of the pan. If it is attracted, the pan is suitable for induction.
- If you do not have a magnet:
  1. Put some water in the pan you want to check.
  2. Follow the steps under 'to start cooking'.
  3. If the Unsuitable Cookware icon (⏏) does not flash in the display and the water is heating, the pan is suitable.
- Cookware made from the following materials is not suitable: pure stainless steel, aluminium or copper without a magnetic base, glass, wood, porcelain, ceramic, and earthenware.
- **DO NOT** use cookware with jagged edges or a curved base.
- Make sure that the base of your pan is smooth, sits flat against the glass, and is the same size as the cooking zone. Always centre your pan on the cooking zone.
- Always lift pans off the hob - **DO NOT** slide or the glass may be scratched.

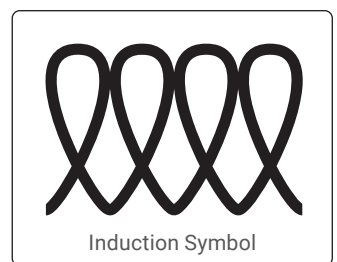

## HEATING

- To turn the unit on, touch the On/Off button (1). The unit will 'beep', all indicators will light up for one second, go out and the unit will be in standby mode.
- Place a suitable pan on the cooking zone that you wish to use. Make sure the bottom of the pan and the surface of the cooking zone are clean and dry.
- Select the heating zone to be used, the power level indicator will flash (2) and select a heat setting by using the Increase / Decrease button (3).
- The hob has a power management system which is activated if too many hob elements are running on high settings. Elements may reduce their set value or shut off automatically.
- **NOTE:** If no heat setting is selected, the hob will turn off within one minute. The heat setting can be modified at any time during cooking.
- When you have finished cooking, select the zone and using the Decrease button return the setting to '0' (5).
- Touch the On/Off button (1) to turn the whole hob off.

## BOOST FUNCTION

- Each zone can be run in boost mode which can be selected by touching the power boost button until the power level for the selected zone displays 'P' (4).
- To cancel boost, touch the zone button and then select the power level using the '-' and '+' buttons.

## RESIDUAL HEAT WARNING

- After any of the zones have been used there will be some residual heat. The letter 'H' will be displayed next to the zone(s) that are still hot and must not be touched.
- **WARNING! IF A HEATING ZONE IS HOT, IT IS LABELLED 'H'. DO NOT TOUCH THE SURFACE.**

## CHILD LOCK

- The hob can be locked to prevent unintended use.
- When the lock function is enabled, all the controls except the On/Off control are disabled.
- To lock the controls, touch and hold the child lock button for 3 seconds. The timer indicator will display 'Lo'.
- To unlock, make sure the hob is turned on, and touch the child lock button for 3 seconds.

## TIMER

- The timer can be used to simply measure time elapsed or to turn off a zone once the set time is reached. The timer can be set between 1 and 99 minutes.
- To measure time elapsed make sure the hob is turned on and no zone selection key is activated (zone indication '-' is not blinking).
- **NOTE:** You can set a timer before or during cooking.
- Touch timer key, "00" will show in the timer display and the right hand "0" will blink (8).
- Set the time by touching the "+" "-" controls. To set beyond 9 minutes, touch the timer button again and the left hand "0" will blink (9). Use the "+" "-" controls to set your required time.
- When the time is set, it will begin to count down immediately. The display will show the remaining time.
- **NOTE:** A red dot will appear against the relevant zone indicator to indicate which zone or zones are being timed (10).
- When the timer has finished, a buzzer will sound for 30 seconds and the timer indicator will show "--" when the set time has elapsed (11).
- To set a timer for more than one zone, select another zone as required and repeat the process.
- When more than one zone is being timed you can select a zone to see the timer status which is indicated by a flashing red dot. Any other timed zone is indicated with a static red dot (12).
- To cancel a timer, touch the zone control, then touch the decrease control to set the timer to "0".

## AUTO SHUTDOWN

- The hob has an automatic shutdown safety feature. If you forget to switch off a cooking zone the default shutdown times are as follows:
  1. Power Level 1,2 or 3: 8 hours
  2. Power Level 4, 5 or 6: 4 hours
  3. Power Level 7, 8 or 9: 2 hours

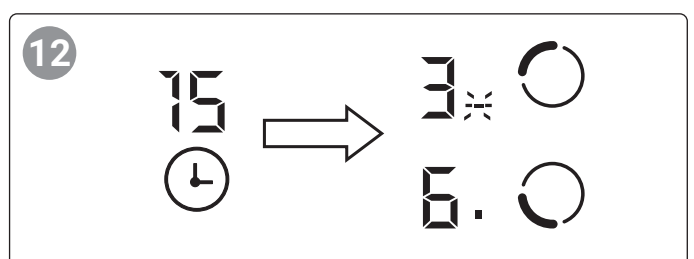
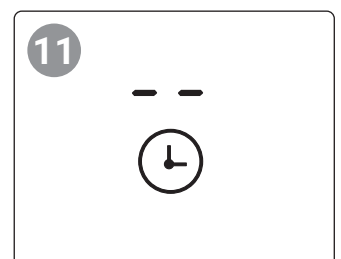
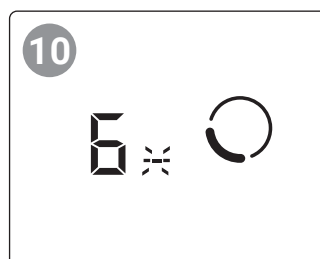
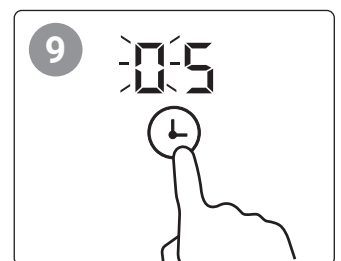
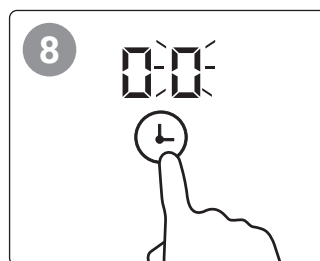
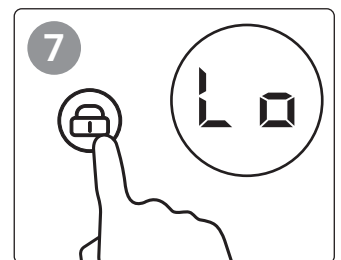
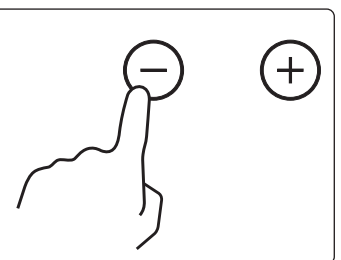
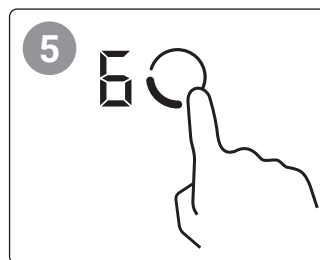
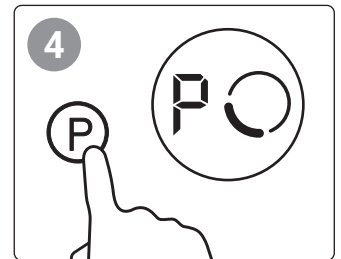
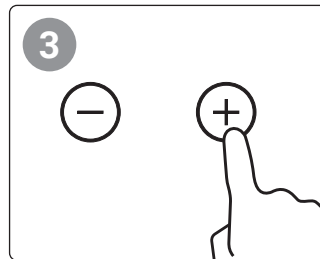
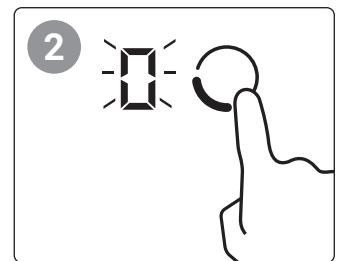
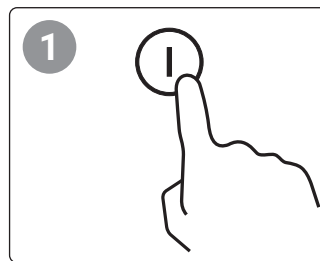

## Maintenance

- Always disconnect the power supply prior to cleaning the appliance. If the switched fused connection unit is difficult to reach, shut off the power supply by using the corresponding circuit breaker at the distribution board.
- Clean the appliance thoroughly before first use. The hob should be cleaned regularly and any food deposits removed.
- Never clean the hob surfaces by steam cleaning.
- The hob ceramic should only be cleaned with warm soapy water, using either a sponge or soft cloth. No abrasive cleaners should be used.
- Any stains that may appear on the hob will have originated from food splashes or spilt food, these splashes occur during the cooking process. These could possibly be a result of the food being cooked at an excessively high temperature or being placed in cookware that is too small.
- You should select a cooking temperature and function that is appropriate for the food that you are cooking. You should also ensure that the food is placed in an adequately sized dish and that you use a drip tray where appropriate.
- Regularly check for any signs of wear or damage to the surface and control panel. Address any issues promptly to prevent further damage.

Problem	Solution	Note
Everyday soiling on glass (fingerprints, marks, stains left by food or non-sugary spills on the glass.	<ol style="list-style-type: none"> <li>1. Switch the power to the hob off.</li> <li>2. Apply a hob cleaner while the glass is still warm (but not hot!).</li> <li>3. Rinse and wipe dry with a clean cloth or paper towel.</li> <li>4. Switch the power to the hob back on.</li> </ol>	<ul style="list-style-type: none"> <li>• When the power to the hob is switched off, there will be no 'hot surface' indication but the cooking zone may still be hot! Take extreme care.</li> <li>• Heavy-duty scourers, some nylon scourers and harsh/abrasive cleaning agents may scratch the glass. Always read the label to check if your cleaner or scourer is suitable.</li> <li>• Never leave cleaning residue on the hob: the glass may become stained.</li> </ul>
Boilovers, melts, and hot sugary spills on the glass.	<p>Remove these immediately with a fish slice, palette knife or razor blade scraper suitable for ceramic glass hobs, but beware of hot cooking zone surfaces:</p> <ol style="list-style-type: none"> <li>1. Switch the power to the hob off at the wall.</li> <li>2. Hold the blade or utensil at a 30° angle and scrape the soiling or spill to a cool area of the hob.</li> <li>3. Clean the soiling or spill up with a dish cloth or paper towel.</li> <li>4. Follow steps above for everyday soiling on glass.</li> </ol>	<ul style="list-style-type: none"> <li>• Remove stains left by melts and sugary food or spillovers as soon as possible. If left to cool on the glass, they may be difficult to remove or even permanently damage the glass surface.</li> <li>• Cut hazard: when the safety cover is retracted, the blade in a scraper is razor-sharp. Use with extreme care and always store safely and out of reach of children.</li> </ul>
Spills on the touch panel.	<ol style="list-style-type: none"> <li>1. Switch the power to the hob off.</li> <li>2. Soak up the spill.</li> <li>3. Wipe the touch control area with a clean damp sponge or cloth.</li> <li>4. Wipe the area completely dry with a paper towel.</li> <li>5. Switch the power to the hob back on.</li> </ol>	The hob may beep and turn itself off, and the touch controls may not function while there is liquid on them. Make sure you wipe the touch control area dry before turning the hob back on.

## Troubleshooting

Problem	Possible Cause	Solution
The hob cannot be turned on.	No power.	<p>Make sure the hob is connected to the power supply and that it is switched on.</p> <p>Check whether there is a power outage in your home or area. If you've checked everything and the problem persists, call a qualified technician.</p>
The touch controls are unresponsive.	The controls are locked.	Unlock the controls. See Operation section for instructions.
The touch controls are difficult to operate.	There may be a slight film of water over the controls or you may be using the tip of your finger when touching the controls.	Make sure the touch control area is dry and use the ball of your finger when touching the controls.
The glass is being scratched.	Rough-edged cookware. Unsuitable, abrasive scourer or cleaning products being used.	Use cookware with flat and smooth bases. See 'Choosing the right cookware'. See 'Care and cleaning'.
Some pans make crackling or clicking noises.	This may be caused by the construction of your cookware (layers of different metals vibrating differently).	This is normal for cookware and does not indicate a fault.

## Troubleshooting (cont.)

Problem	Possible Cause	Solution
Some pans make crackling or clicking noises.	This may be caused by the construction of your cookware (layers of different metals vibrating differently).	This is normal for cookware and does not indicate a fault.
The induction hob makes a low humming noise when used on a high heat setting.	This is caused by the technology of induction cooking.	This is normal, but the noise should quieten down or disappear completely when you decrease the heat setting.
Fan noise coming from the induction hob.	A cooling fan built into your induction hob has come on to prevent the electronics from overheating. It may continue to run even after you've turned the induction hob off.	This is normal and needs no action. Do not switch the power to the induction hob off at the wall while the fan is running.
Pans do not become hot and appears in the display.	The induction hob cannot detect the pan because it is not suitable for induction cooking. The induction hob cannot detect the pan because it is too small for the cooking zone or not properly centred on it.	Use cookware suitable for induction cooking. See section 'Choosing the right cookware'. Centre the pan and make sure that its base matches the size of the cooking zone.
The induction hob or a cooking zone has turned itself off unexpectedly, a tone sounds and an error code is displayed (typically alternating with one or two digits in the cooking timer display).	Technical fault.	Please note down the error letters and numbers, switch the power to the induction hob off at the wall, and contact a qualified technician.

## Error Codes

Error Code	Type Of Fault	Solution
E4 / E5	Temperature sensor failure.	Please contact the supplier.
E7 / E8	Temperature sensor of the IGBT failure.	
E2 / E3	Abnormal supply voltage.	Inspect power supply. Power on after the power supply is deemed to be within normal, safe working parameters. Any inspections or repairs must be carried out by a qualified electrician.
E6 / E9	Induction hob heat overload.	Please restart after the induction hob cools down.

## End of Life

- At the end of its service life, this product must be disposed of in an environmentally responsible manner. Components such as metal parts should be recycled wherever possible. **DO NOT** discard the appliance with general household or construction waste. Please follow all local environmental regulations to ensure safe and sustainable disposal.

## Information for domestic electric hobs

	Symbol	Value	Unit
Model Identification		DH177.V2	
Type of hob		Electric hobs	
Number of cooking zones and/or areas		4	
Heating technology (induction cooking zones and cooking areas, radiant cooking zones, solid plates)		Induction cooking	
For circular cooking zones or area: diameter of useful surface area per electric heated cooking zone, rounded to nearest 5mm	∅	Left down: 21.0 Left up: 16.0 Right down: 16.0 Right up: 18.0	cm
For non-circular cooking zones or areas: length and width of useful surface area per electric heated cooking zone or area, rounded to the nearest 5mm	L W		cm
Energy consumption per cooking zone or area calculated per kg	EC <sub>electric cooking</sub>	Left down: 177.6 Left up: 195.4 Right down: 195.4 Right up: 178.6	Wh/kg
Energy consumption for the hob calculated per kg	EC <sub>electric hob</sub>	186.8	Wh/kg



### Environment Protection, Waste Electrical and Waste Electronic Equipment Regulations (WEEE)



Recycle unwanted packaging materials. When this product is no longer required, or has reached the end of its useful life, please dispose of in an environmentally friendly way. Drain any fluids (if applicable) into approved containers, in accordance with local waste regulations.



Please note that this product contains one or more batteries. It is our policy to continually improve products and we reserve the right to alter data, specifications and parts without prior notice. No liability is accepted for incorrect use of this product. Guarantee is 12 months from purchase date, proof of which is required for any claim.



Jack Sealey Ltd t/a Baridi Kempson Way, Suffolk Business Park, Bury St Edmunds, Suffolk, IP32 7AR UK  
 Jack Sealey (EU) Ltd t/a Baridi Farney Street, Carrickmacross, Co. Monaghan, A81 PK68 Ireland  
 Tel: 01284 757575 • Email: support@baridi.co.uk • Web: www.baridi.co.uk