

Thank you for purchasing a Sealey product. Manufactured to a high standard, this product will, if used according to these instructions, and properly maintained, give you years of trouble free performance.



IMPORTANT: PLEASE READ THESE INSTRUCTIONS CAREFULLY. NOTE THE SAFE OPERATIONAL REQUIREMENTS, WARNINGS & CAUTIONS. USE THE PRODUCT CORRECTLY AND WITH CARE FOR THE PURPOSE FOR WHICH IT IS INTENDED. FAILURE TO DO SO MAY CAUSE DAMAGE AND/OR PERSONAL INJURY AND WILL INVALIDATE THE WARRANTY. KEEP THESE INSTRUCTIONS SAFE FOR FUTURE USE.

1. SAFETY

- ❑ **WARNING!** Ensure Health & Safety, local authority, and general workshop practice regulations are adhered to when using this trolley.
- ✗ **DO NOT** overload the trolley (40kg max. per shelf).
- ✗ **DO NOT** drop loads on to shelves.
- ✗ **DO NOT** place hot (above 100°C) items on to shelves.
- ✓ Load shelves with the heaviest items on the lower shelves.
- ✓ Use the trolley in a suitable work area.
- ✓ Keep the work area clean, uncluttered and ensure there is adequate lighting.
- ✓ Keep the trolley clean and tidy in accordance with good workshop practice.
- ✗ **DO NOT** use the trolley for any purpose other than that for which it is designed.
- ✗ **DO NOT** stand on the trolley, use it as a ladder or allow others to ride on the trolley.
- ✓ Use the wheel locks to prevent the trolley from inadvertently moving.
- ✗ **DO NOT** leave unattended, especially when loaded, unless the wheels are locked, chocked or the trolley otherwise secured.
- ✗ **DO NOT** use trolley on uneven ground and **DO NOT** run over curbs or steps - use a ramp.
- ✗ **DO NOT** use trolley if any part is significantly damaged, paying particular attention to the wheels.
- ✓ Keep children and unauthorised persons away from the work area.



2. INTRODUCTION

Composite garage workshop trolley with a 40kg capacity per shelf. Retention lips on only three sides of each shelf allow easy-access when adding or removing items. Four large castors, two locking. May also be used as a janitorial trolley.

3. SPECIFICATION

Model	CX309	Capacity	40kg max. per shelf
Overall Size (W x D x H)	750 x 460 x 980 mm	Nett Weight	9.99kg

4. CONTENTS

Carefully unpack the product and check the contents against the diagram and parts list below. Should any items be missing or damaged contact your Sealey dealer.

Description	Qty	Description	Qty	Description	Qty	Description	Qty
 Shelf (top and middle)	2	 Corner post	8	 Castor	2	 Spanner for castor	1
 Bottom Shelf (for castors)	1	 Handle	2	 Castor (locking)	2	 Bolt for handle	4
						 Washer for handle	4
						 Washer for castor	4

5. ASSEMBLY

- 5.1. Assemble on a bench protecting against scratches.
- 5.1.1. Fit four corner posts to middle and bottom shelf (fig.1).
- 5.1.2. Fit two handles to top shelf with supplied screws (fig.2).
- 5.1.3. Fit all three shelves to corner posts (fig.3).
- 5.1.4. Fix 4 castors and tighten with provided spanner (fig.4).

Orientation Note: Shelves have one flush edge and three retaining edges. The flush edge is the loading edge

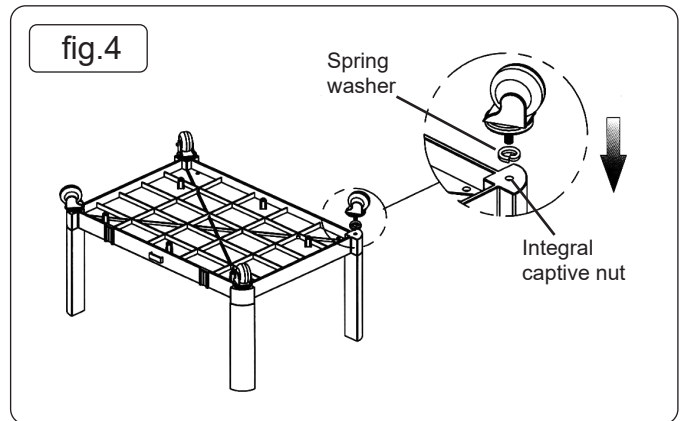
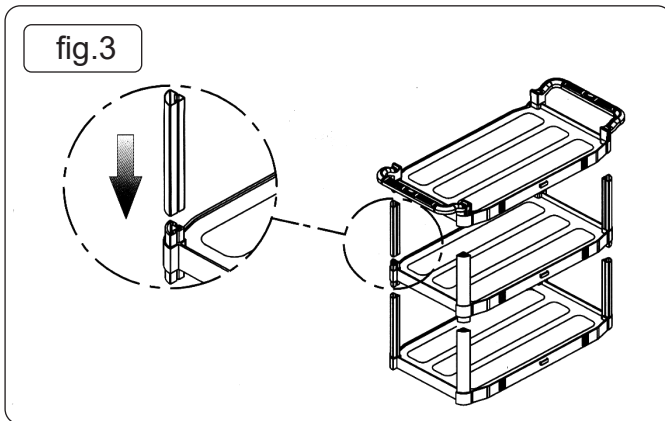
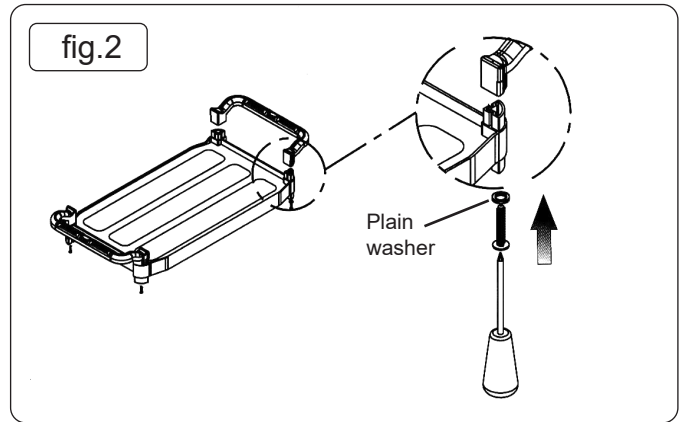
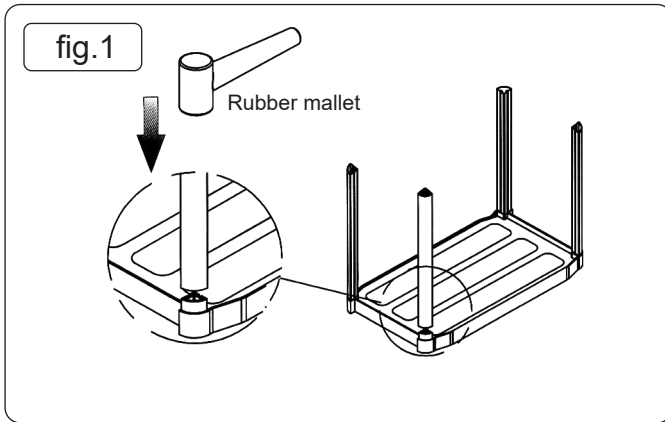

ENVIRONMENT PROTECTION

Recycle unwanted materials instead of disposing of them as waste. All tools, accessories and packaging should be sorted, taken to a recycling centre and disposed of in a manner which is compatible with the environment. When the product becomes completely unserviceable and requires disposal, drain any fluids (if applicable) into approved containers and dispose of the product and fluids according to local regulations.



Note: It is our policy to continually improve products and as such we reserve the right to alter data, specifications and component parts without prior notice.

Important: No Liability is accepted for incorrect use of this product.

Warranty: 12 month guarantee. Proof of which is required for any claim.

Jack Sealey Ltd t/a Sealey Group Kempson Way, Suffolk Business Park, Bury St Edmunds, Suffolk, IP32 7AR UK

Jack Sealey (EU) Ltd t/a Sealey Group Farnley Street, Carrickmacross, Co. Monaghan, A81 PK68 Ireland

Tel: 01284 757500 • Email: sales@sealey.co.uk • Web: www.sealey.co.uk