



AMERICAN PRO® 5 DRAWER ROLL CAB AMERICAN PRO® 3 DRAWER TOP CHEST

MODEL NOS: AP1101G, AP1102G

Thank you for purchasing a Sealey product. Manufactured to a high standard, this product will, if used according to these instructions, and properly maintained, give you years of trouble free performance.



IMPORTANT: PLEASE READ THESE INSTRUCTIONS CAREFULLY. NOTE THE SAFE OPERATIONAL REQUIREMENTS, WARNINGS & CAUTIONS. USE THE PRODUCT CORRECTLY AND WITH CARE FOR THE PURPOSE FOR WHICH IT IS INTENDED. FAILURE TO DO SO MAY CAUSE DAMAGE AND/OR PERSONAL INJURY AND WILL INVALIDATE THE WARRANTY. KEEP THESE INSTRUCTIONS SAFE FOR FUTURE USE.

1. SAFETY

- WARNING!** Ensure Health & Safety, local authority, and general workshop practice regulations are adhered to when using this rollcab and topchest.
- ✓ Locate the rollcab and topchest in a suitable working area.
- ✓ Use on level and solid ground, preferably concrete.
- ✓ Keep the work area clean, uncluttered and ensure that there is adequate lighting.
- ✓ Keep rollcab and topchest clean and tidy in accordance with good workshop practice.
- ✓ Keep children and unauthorised persons away from the working area.
- ✗ **DO NOT** use the rollcab and topchest for any purpose other than that for which it is designed.
- ✗ **DO NOT** move the rollcab and topchest with drawers open. To avoid tipping, open one drawer at a time and close and secure all drawers whilst moving.
- ✗ **DO NOT** overload or step on the drawers.
- ✗ **DO NOT** place the rollcab and topchest in a damp or wet location or an area where there is condensation.
- ✗ **DO NOT** clean the rollcab and topchest with any solvents which may damage the surfaces or the protective coating.
- WARNING!** The warnings, cautions and instructions referred to in these instructions cannot cover all possible conditions and situations that may occur. It must be understood that common sense and caution are factors which cannot be built into this product, but must be applied by the operator.

2. INTRODUCTION

AP1101G Rollcab

All steel construction and manufactured with steel inner walls for extra strength and durability. Powder coated finish resists rust and solvent spills. Supplied with four Ø5" x 2" castors, two fixed and two swivel with brakes and a powder coated side handle. Fitted with a cylinder lock and locking bar to secure drawers. Supplied with two keys.

AP1102G Topchest

Steel construction and manufactured with steel inner walls for extra strength and durability and powder-coated finish resists rust and spills. Fitted with a cylinder lock and locking bar to secure drawers. Supplied with two keys.



AP1102G



AP1101G



3. SPECIFICATION

Model	AP1101G	Small Drawer (x1)	External: 824 x 415 x 78 mm Internal: 805 x 392 x 63 mm
Overall Size (W x D x H)	With Handle: 995 x 461 x 942 mm Without Handle: 913 x 461 x 942 mm	Medium Drawer (x3)	External: 824 x 415 x 106 mm Internal: 805 x 392 x 91 mm
Nett Weight	49kg	Large Drawer (x1)	External: 824 x 415 x 232 mm Internal: 805 x 392 x 213 mm

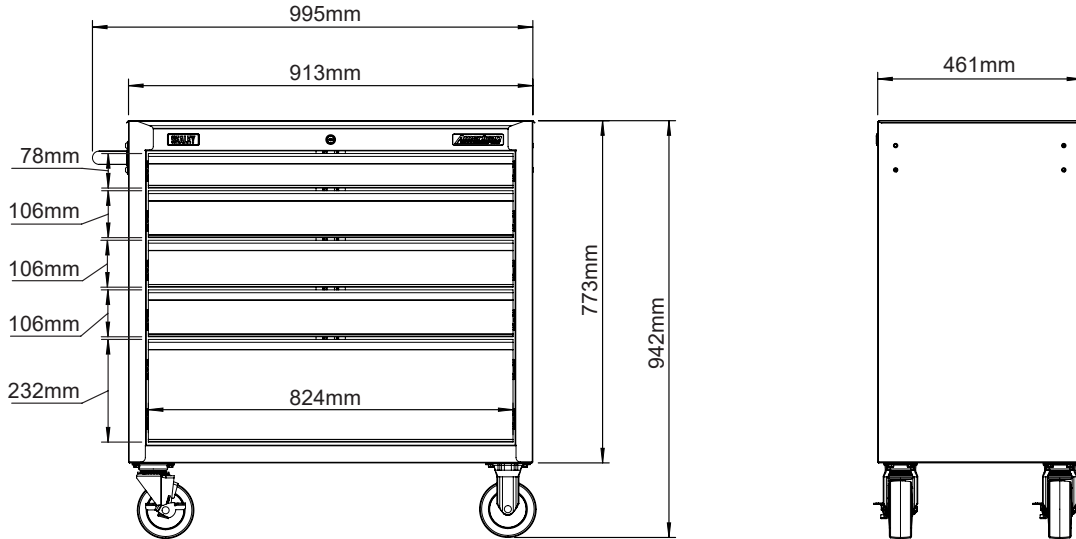

Model	AP1102G
Overall Size (W x D x H)	906 x 453 x 359 mm
Small Drawer (x2)	External: 816 x 435 x 55 mm / Internal: 787 x 406 x 44 mm
Medium Drawer (x1)	External: 816 x 435 x 115 mm / Internal: 787 x 406 x 104 mm
Nett Weight	29.7kg

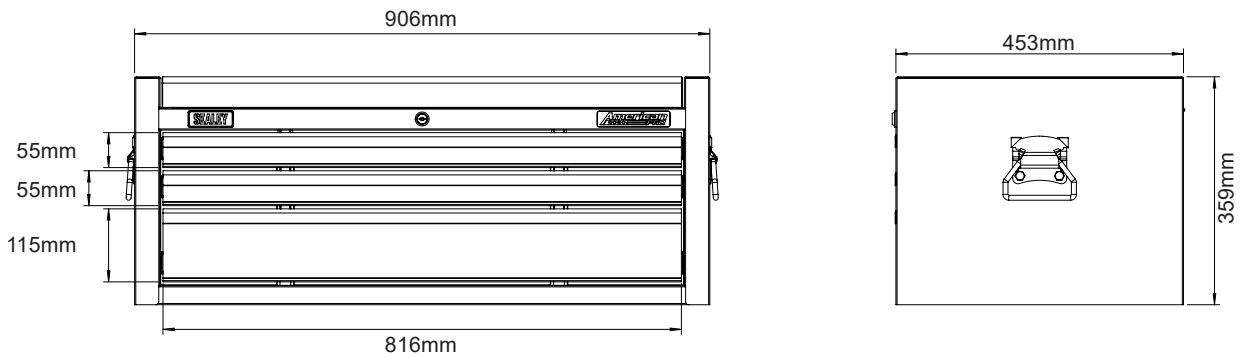

4. ASSEMBLY

- ❑ **WARNING!** These units are heavy, obtain the help of at least one other person before attempting to unpack and move them.
- 4.1. Attach the wheels to the bottom of the rollcab using 4 bolts per wheel (fig.1). The braked swivel wheels should be mounted on the same end as the side mounted handle.
- 4.2. Mount the side mounted handle onto the cabinet and attach with 4 bolts (fig.3).
- 4.3. To remove a drawer with roller sliders, pull the drawer out completely, press down the right tab and lift up the left tab, pull the drawer off the slides (fig.2). To reinstall the drawer, realign with the internal drawer slide and push until it locks in place.
IMPORTANT: To avoid tipping, open one drawer at a time and close and secure all drawers whilst moving the topchest/rollcab.

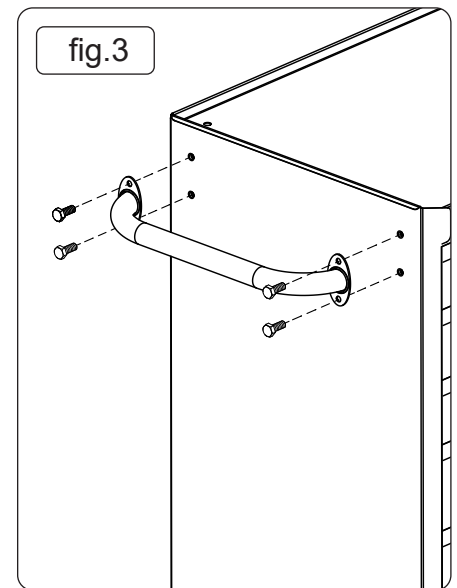
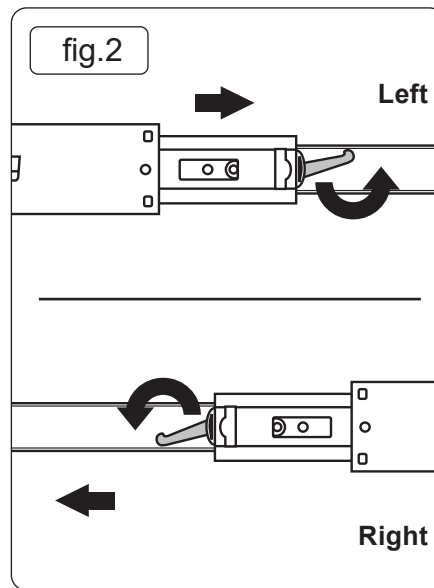
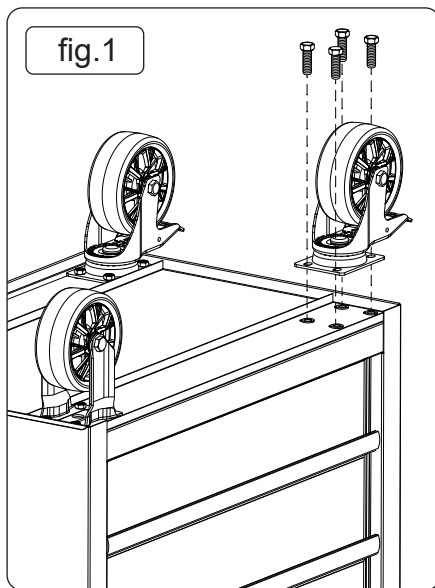

5. OPERATION

- ❑ **WARNING!** Only open one drawer at a time and **DO NOT** overload the drawers.
- ❑ **WARNING!** When moving the rollcab, ensure that all drawers are closed, release the two brakes and move the rollcab using the handle to maintain full control. When the rollcab has been moved to the required location, lock the brakes.
NOTE: For extra safety, it is recommended that the rollcab/topchest is locked using the key, before relocation, this engages the locking bar which prevents all drawers from opening.
- ❑ **WARNING! DO NOT** move across slopes of more than 5° as the rollcab may tilt over.

6. MAINTENANCE

- 6.3.1. Periodically lubricate castors and drawer runners and tighten all hardware.
- 6.3.2. Clean the surfaces with a soft cloth and a mild water/detergent solution.
- 6.3.3. Stubborn grease and oil marks can be removed by using a non-abrasive cleaner.



ENVIRONMENT PROTECTION

Recycle unwanted materials instead of disposing of them as waste. All tools, accessories and packaging should be sorted, taken to a recycling centre and disposed of in a manner which is compatible with the environment. When the product becomes completely unserviceable and requires disposal, drain any fluids (if applicable) into approved containers and dispose of the product and fluids according to local regulations.



Note: It is our policy to continually improve products and as such we reserve the right to alter data, specifications and component parts without prior notice.

Important: No Liability is accepted for incorrect use of this product.

Warranty: 24 month guarantee. Proof of which is required for any claim.

Jack Sealey Ltd t/a Sealey Group Kempson Way, Suffolk Business Park, Bury St Edmunds, Suffolk, IP32 7AR UK

Jack Sealey (EU) Ltd t/a Sealey Group Farnley Street, Carrickmacross, Co. Monaghan, A81 PK68 Ireland

Tel: 01284 757500 • Email: sales@sealey.co.uk • Web: www.sealey.co.uk