

SEALEY

HEAVY-DUTY STEEL MOBILE WORKBENCH WITH WOODEN WORKTOP 1524MM

MODEL NO: **AP0620M**

Thank you for purchasing a Sealey product. Manufactured to a high standard, this product will, if used according to these instructions, and properly maintained, give you years of trouble free performance.

IMPORTANT: PLEASE READ THESE INSTRUCTIONS CAREFULLY. NOTE THE SAFE OPERATIONAL REQUIREMENTS, WARNINGS & CAUTIONS. USE THE PRODUCT CORRECTLY AND WITH CARE FOR THE PURPOSE FOR WHICH IT IS INTENDED. FAILURE TO DO SO MAY CAUSE DAMAGE AND/OR PERSONAL INJURY AND WILL INVALIDATE THE WARRANTY. KEEP THESE INSTRUCTIONS SAFE FOR FUTURE USE.



Refer to instruction manual

1. SAFETY

- ❑ **WARNING!** Ensure Health & Safety, local authority, and general workshop practice regulations are adhered to when using this workbench.
 - ❑ **WARNING!** Use workbench on level and solid ground, preferably concrete. Avoid tarmacadam since the workbench may sink into the surface.
 - ✓ Locate workbench in a suitable working area.
 - ✓ Keep the work area clean, uncluttered and ensure there is adequate lighting.
 - ✓ Keep the workbench clean and tidy in accordance with good workshop practice.
 - ✓ Keep children and unauthorised persons away from the working area.
 - ✗ **DO NOT** use the workbench for any purpose other than that for which it is designed.
 - ✗ **DO NOT** undertake work on the workbench without the workpiece being adequately secured. Use clamps or a vice (not included) to secure the workpiece. Available from your Sealey stockist.
 - ✗ **DO NOT** use the workbench out of doors.
 - ✗ **DO NOT** get the workbench wet or use in damp or wet locations or areas where there is condensation.
 - ✗ **DO NOT** clean the workbench with any solvents which may damage the work surface or the painted surfaces.
- Note! The assembly of this product will require assistance.**

2. INTRODUCTION

Manufactured from heavy gauge steel for long lasting strength. Power bar included, featuring 4 x 230V sockets, 3 x 5V (2.4A) USB ports and a 5V (3A) USB C ports. Full length soft close drawer with heavy-duty 35mm ball-bearing drawer slides. Fitted with four Ø72.5mm locking castors and 30mm wooden worktop.

3. SPECIFICATION

Model	AP0620M
Overall Size (W x D x H)	1524 x 559 x 900mm
Nett Weight	41.1kg
Capacity	500kg

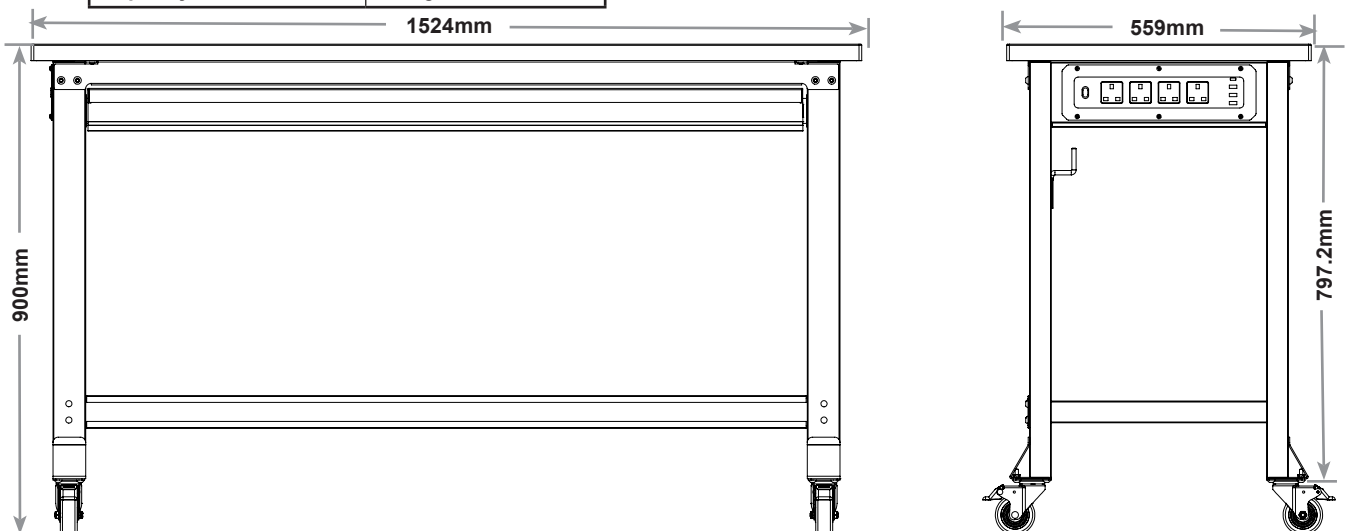

4. CONTENTS

Note: Ensure all components are present. If any components are missing, do not proceed with assembly and contact Sealey.

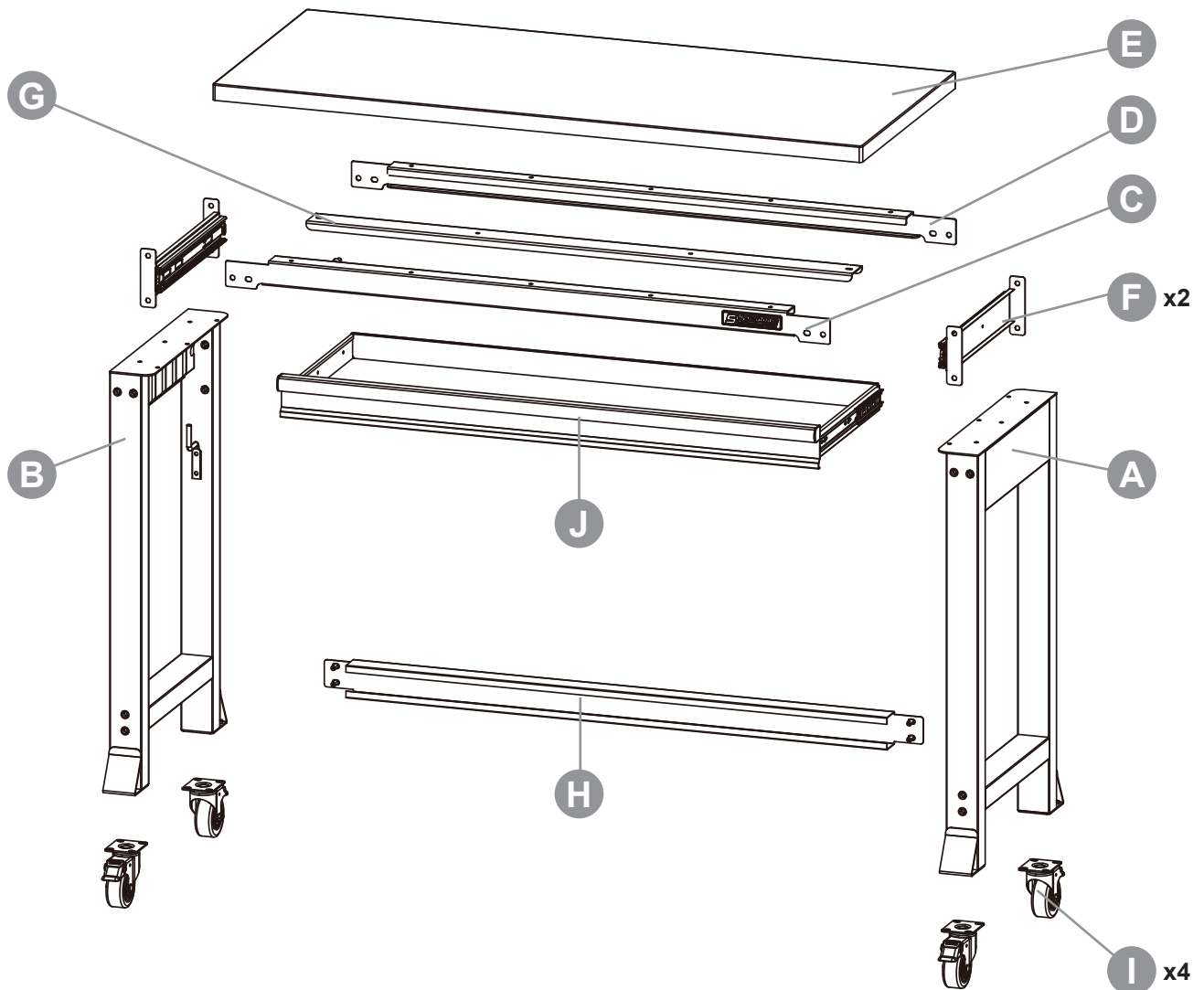

Part	Description	Qty
A	Right Leg	1
B	Left Leg	1
C	Front Beam	1
D	Rear Beam	1
E	Worktop	1
F	Drawer Rail	2
G	Support Rod	1
H	Lower Beam	1
I	Swivel Castor	4
J	Drawer	1
K	#5x15mm crosshead self-tapping screw	24
L	M8x16mm hex bolt	20
M	M6x20mm hex bolt	16
N	M6 spring washer	16
O	M6 washer	16

Tools Required (not included)	
PH2 Screwdriver	
5mm Hex Key	

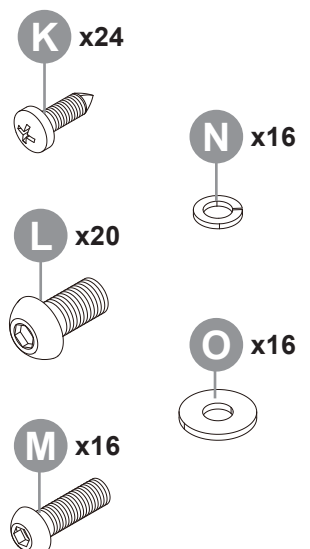

5. ASSEMBLY

1

Note: Do not fully tighten all fixings until the final step.

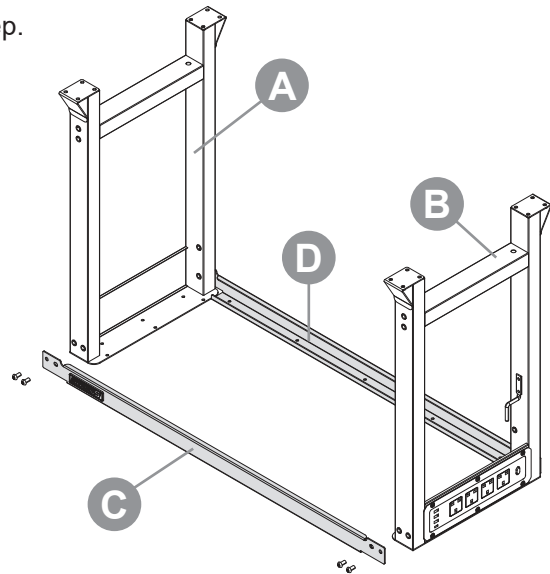
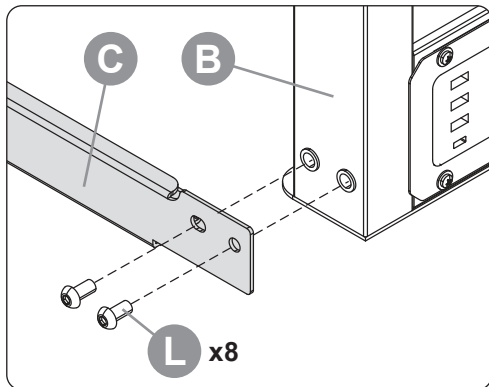

2

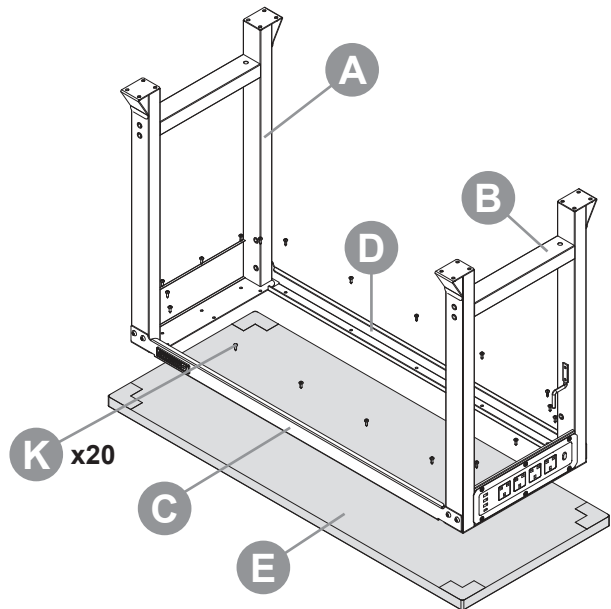
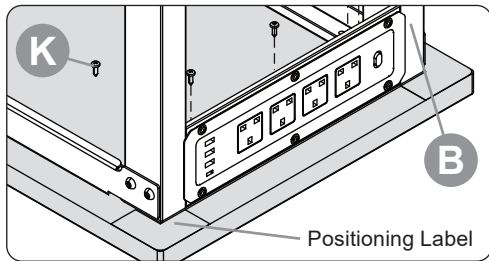
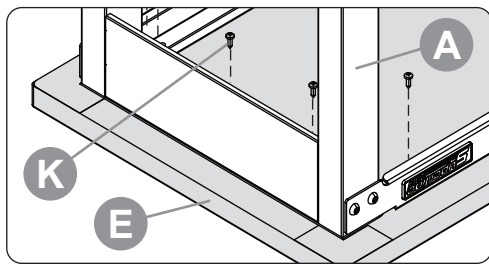

3

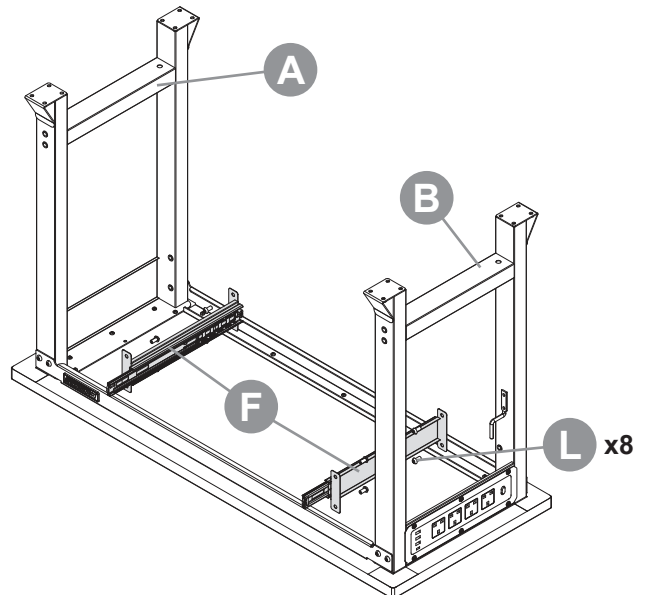
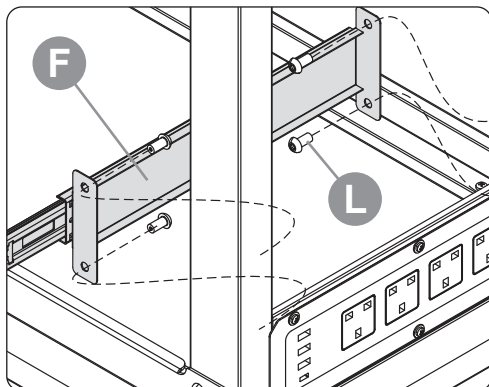

4

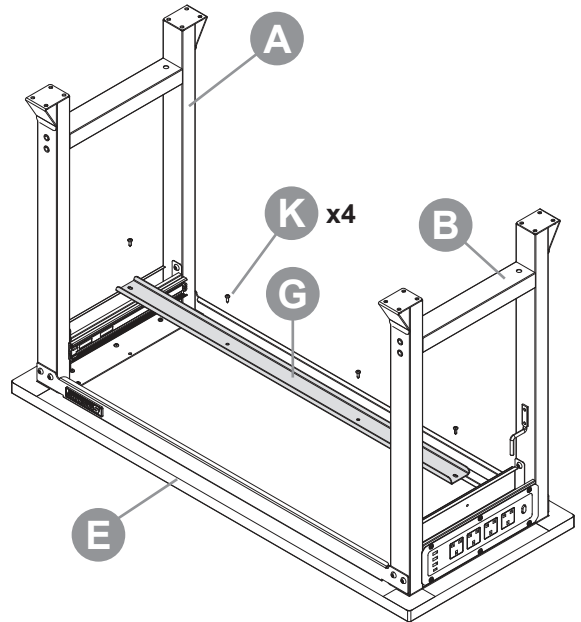
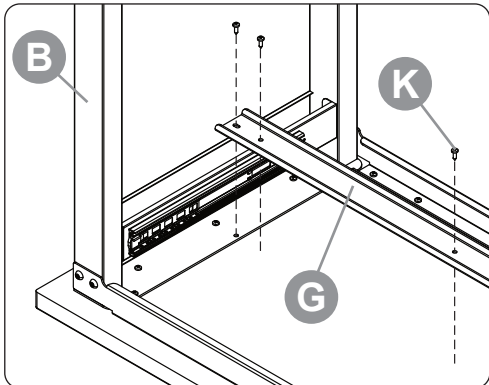

5

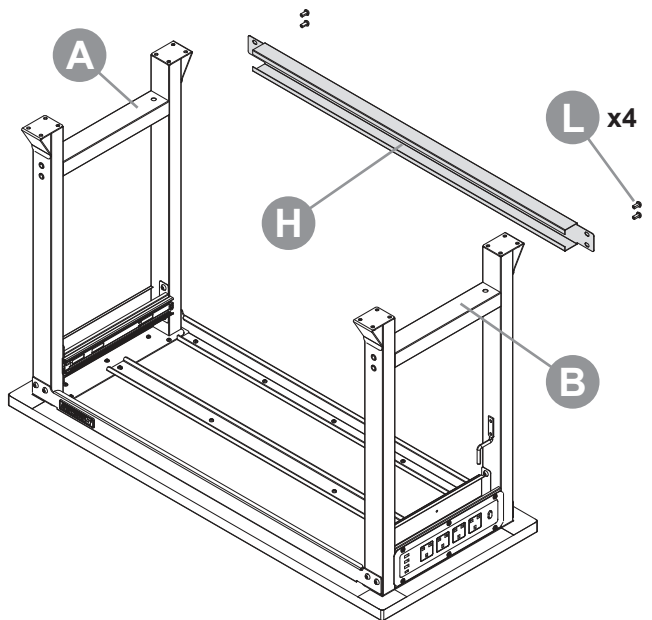
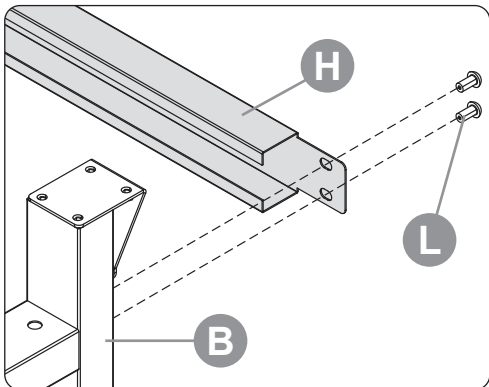

6

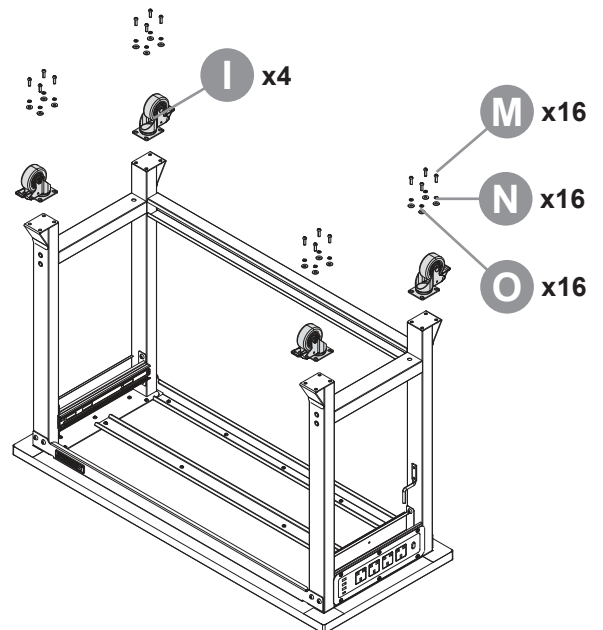
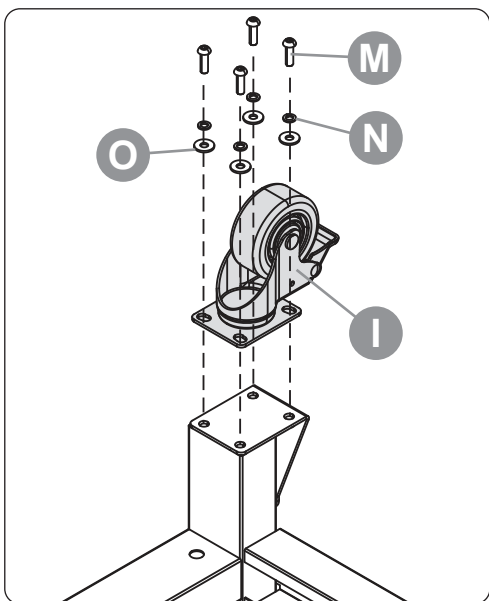

7

Insert the drawer: Pull out both drawer rails until fully extended. Align the slides on the drawer with the drawer rails. Slightly insert one side and repeat for the other side. Slowly push the drawer until it is fully closed in order to engage the drawer stops.

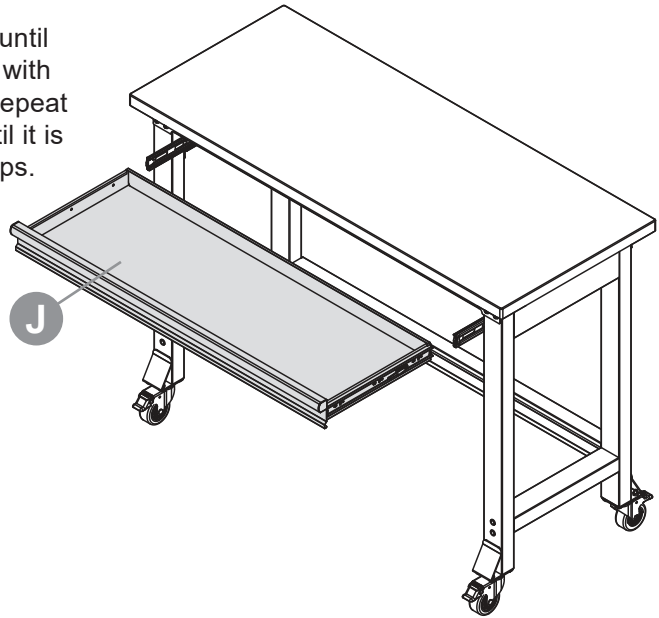
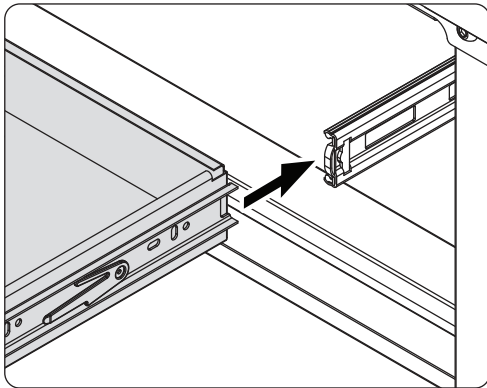

Drawer Release: Fully empty the drawer and extend out all the way. Push up the release lever on the left side and push down the release lever on the right side.

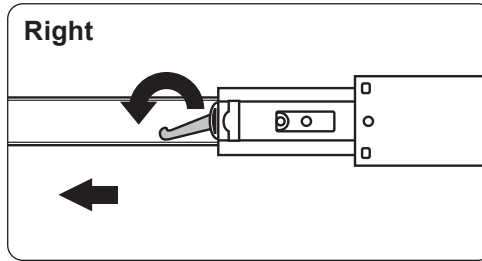
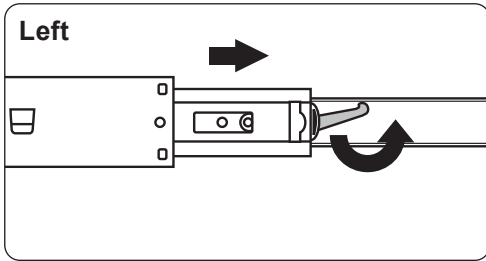

WEEE REGULATIONS

Dispose of this product at the end of its working life in compliance with the EU Directive on Waste Electrical and Electronic Equipment (WEEE). When the product is no longer required, it must be disposed of in an environmentally protective way. Contact your local solid waste authority for recycling information.



ENVIRONMENT PROTECTION

Recycle unwanted materials instead of disposing of them as waste. All tools, accessories and packaging should be sorted, taken to a recycling centre and disposed of in a manner which is compatible with the environment. When the product becomes completely unserviceable and requires disposal, drain any fluids (if applicable) into approved containers and dispose of the product and fluids according to local regulations.



REGISTER YOUR PURCHASE HERE

Note: It is our policy to continually improve products and as such we reserve the right to alter data, specifications and component parts without prior notice.

Important: No Liability is accepted for incorrect use of this product.

Warranty: Guarantee is 60 months from purchase date. Proof of which is required for any claim.

Jack Sealey Ltd t/a Sealey Group, Kempson Way, Suffolk Business Park, Bury St Edmunds, Suffolk, IP32 7AR UK
Jack Sealey (EU) Ltd t/a Sealey Group, Farney Street, Carrickmacross, Co. Monaghan, A81 PK68 Ireland
Tel: 01284 757500 · Email: sales@sealey.co.uk · Web: www.sealey.co.uk